

MDTools[®] 775

What's New

The 20th generation manifold design software



MDTools® 775 What's New

- Auto Circular Pattern
- Improved Create Block Interface
- Create Block Using Plate as a Material type
- Edit Mandatory O-rings
- Preview Angular Connection
- Mirror Footprint
- Make Footprint Outline
- Dimension only Selected Cavity Types
- Create Cavity Dimensions as Individual Ordinates
- Drawing Dimensions Automatically Updated
- Machining Chart Automatically Updated
- Miscellaneous List Automatically Updated
- Balloons/Annotations Automatically Updated
- Fast and Secure Cloud-based License Activation
- MDTools Help: Online and Offline
- Improved Offset Connection
- Suppressed State of Undercut and Slot Displayed
- MDTools Library Manager 2019
- Manage Materials Bars
- Manage Materials Plates
- Add/Modify Materials and Allowances



Auto Circular Pattern

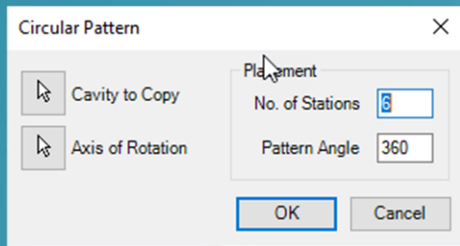

Cavity to copy

Select Inventor axis of rotation or a cavity to create pattern around

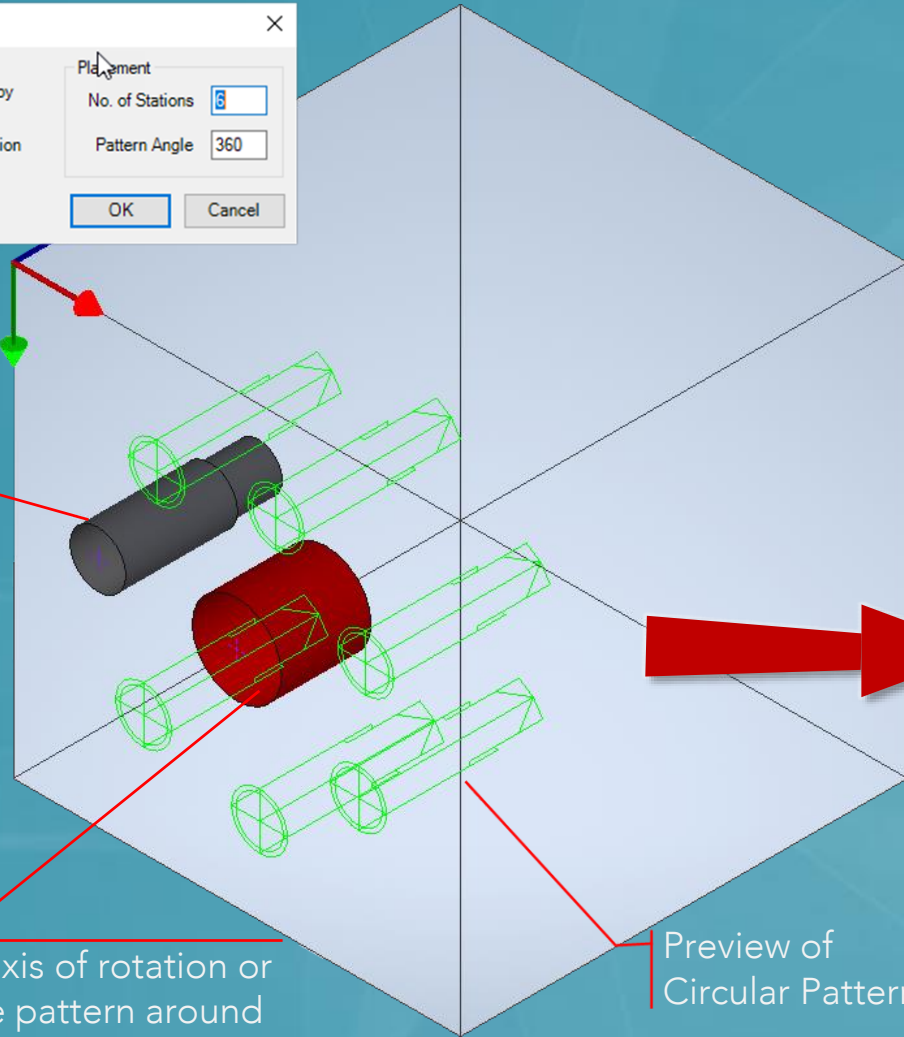

Preview of Circular Pattern

Finished Circular Pattern

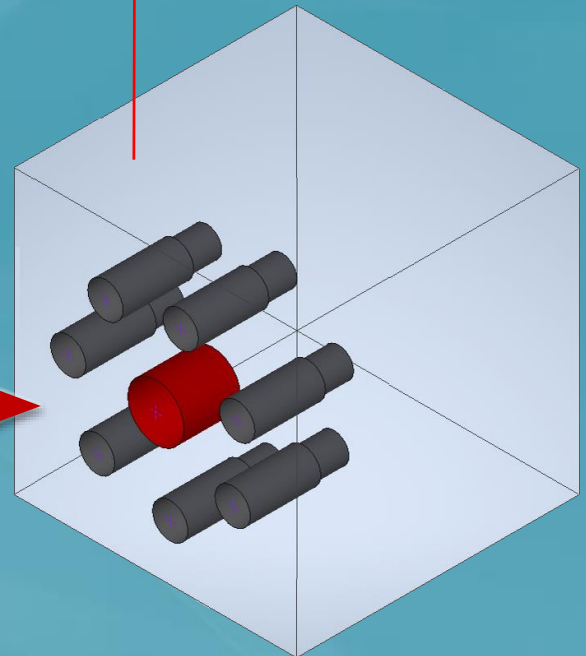



Improved Create Block Interface

Define Machining Allowance for the material either manually or in MDTools Library Manager

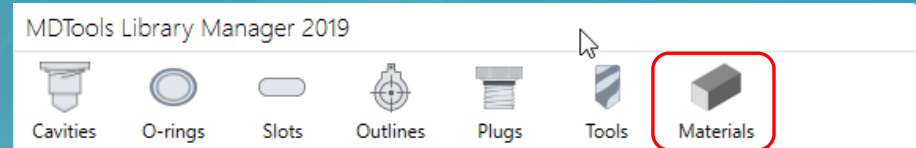
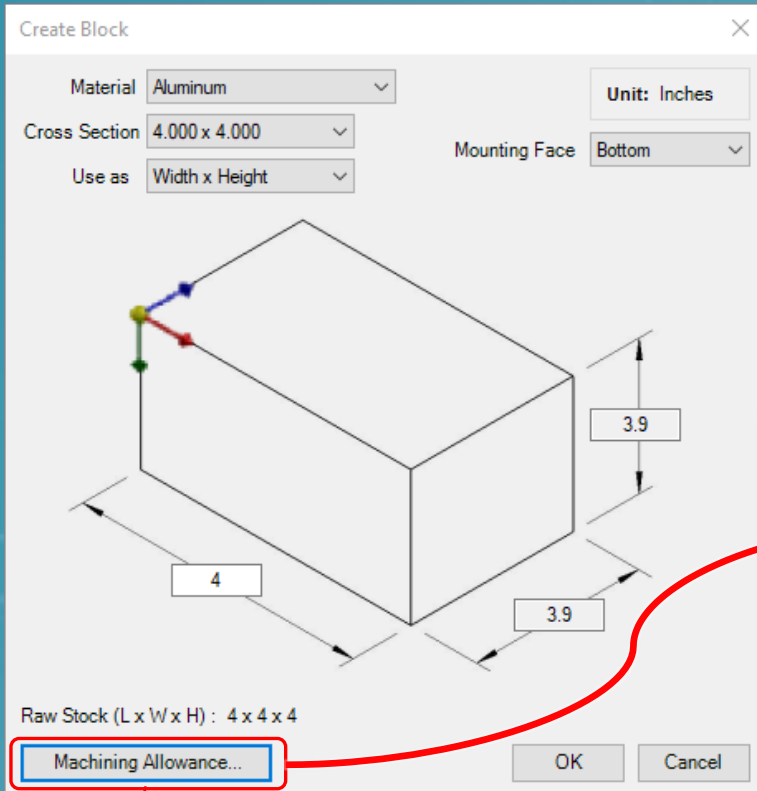

Materials standardized in MDTools Library Manager

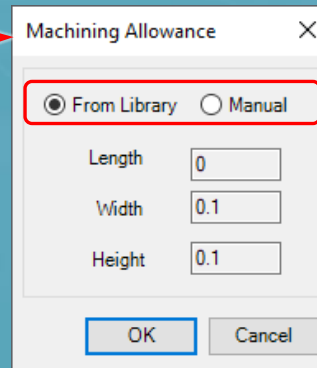

View both Raw Stock and machined dimensions of the block



Create Block Using Plate as a Material Type

Manage Plate Thickness and Machining Allowance in MDTools Library Manager

Use Plate as a Material type

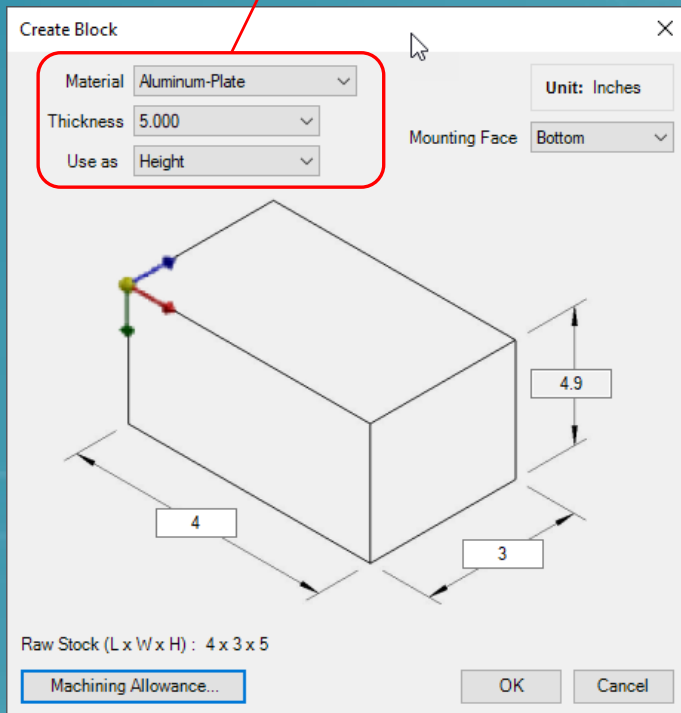

Manage thickness of plates and machining allowance

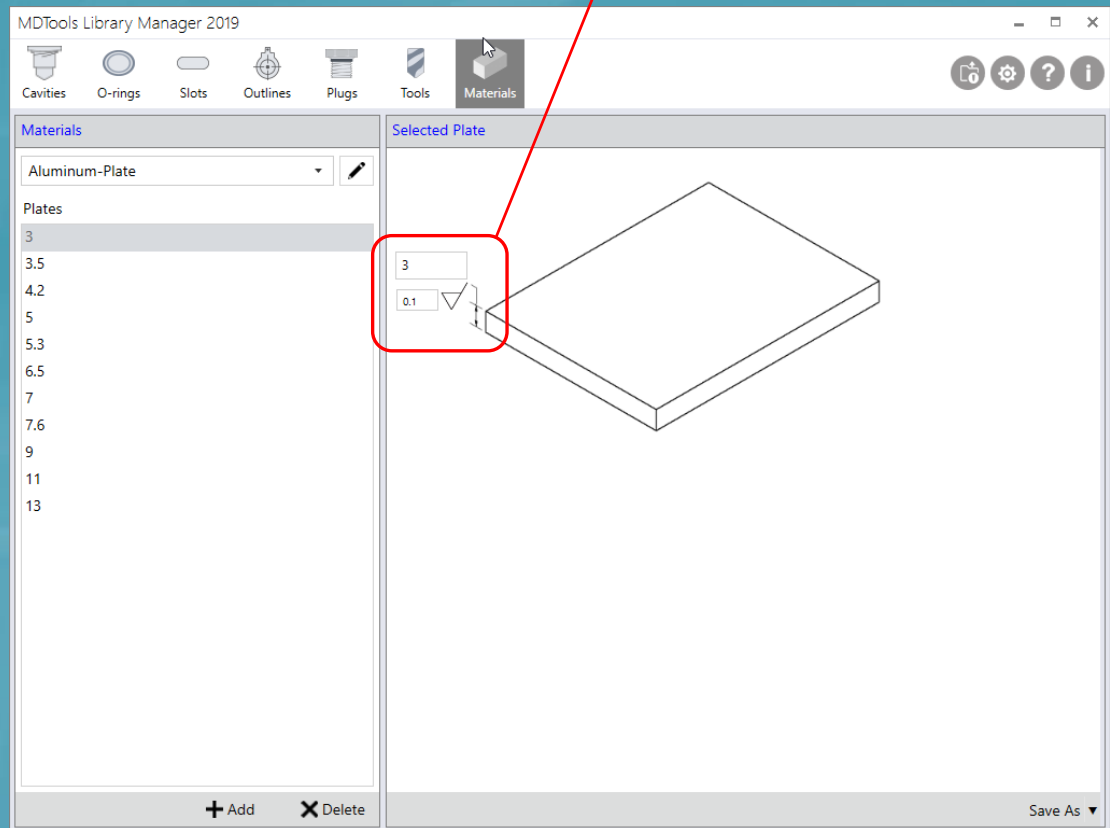



Edit Mandatory O-rings

Component ID: p1 O-ring
Machining ID: ?

Groove Counter Bore

Dash #	ID	OD	Width
-012	3/8	1/2	1/16
-013	7/16	9/16	1/16
-014	1/2	5/8	1/16
-015	9/16	11/16	1/16
-016	5/8	3/4	1/16
-017	11/16	13/16	1/16

Show All

Operation	Diameter	Depth	Remarks
O-RING GROOVE	0.5	0.05	REFER DET

OK Cancel

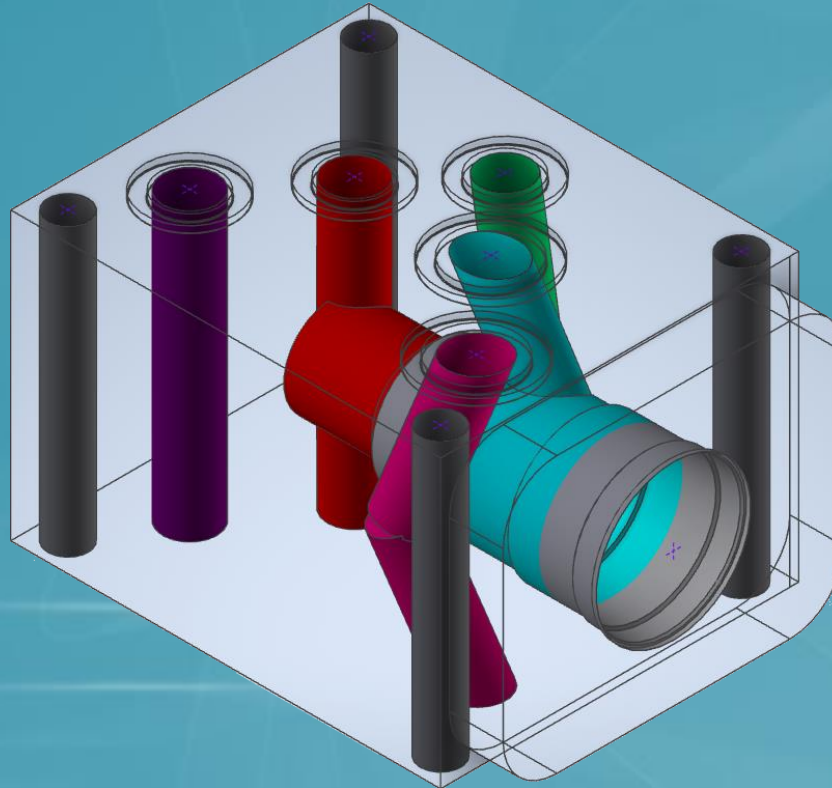

MDTools Library Manager

Select O-ring

Dash#	ID	OD	Width	Is C' Bore
-011	5/16	7/16	1/16	<input type="checkbox"/>
-011	5/16	7/16	1/16	<input checked="" type="checkbox"/>
-012	3/8	1/2	1/16	<input type="checkbox"/>
-012	3/8	1/2	1/16	<input checked="" type="checkbox"/>
-013	7/16	9/16	1/16	<input checked="" type="checkbox"/>
-013	7/16	9/16	1/16	<input type="checkbox"/>
-014	1/2	5/8	1/16	<input type="checkbox"/>
-014	1/2	5/8	1/16	<input checked="" type="checkbox"/>
-015	9/16	11/16	1/16	<input type="checkbox"/>
-015	9/16	11/16	1/16	<input checked="" type="checkbox"/>
-016	5/8	3/4	1/16	<input type="checkbox"/>
-016	5/8	3/4	1/16	<input checked="" type="checkbox"/>
-017	11/16	13/16	1/16	<input type="checkbox"/>
-017	11/16	13/16	1/16	<input checked="" type="checkbox"/>
-018	3/4	7/8	1/16	<input type="checkbox"/>
-018	3/4	7/8	1/16	<input checked="" type="checkbox"/>
-019	13/16	15/16	1/16	<input type="checkbox"/>
-019	13/16	15/16	1/16	<input checked="" type="checkbox"/>
-020	7/8	1	1/16	<input checked="" type="checkbox"/>
-020	7/8	1	1/16	<input type="checkbox"/>
-021	1-5/16	1-1/16	1/16	<input type="checkbox"/>

Clear OK Cancel

Modify the Mandatory O-rings

Note: Use 'Delete O-ring Groove' Command to delete Mandatory O-ring.





Preview Angular Connection

Modify ports and dimensions while watching the Angular Drill preview for easy visualization

Angular Connection

Connect

	Port	Flow (lpm)
Cavity1	1	12
Cavity2	3	12

Energy Efficiency

Optimize Diameter

Angle Hole

Simple Angle Only

Expected Diameter: 0.234

Cavity ID: PLUG1

Create Hole Cancel

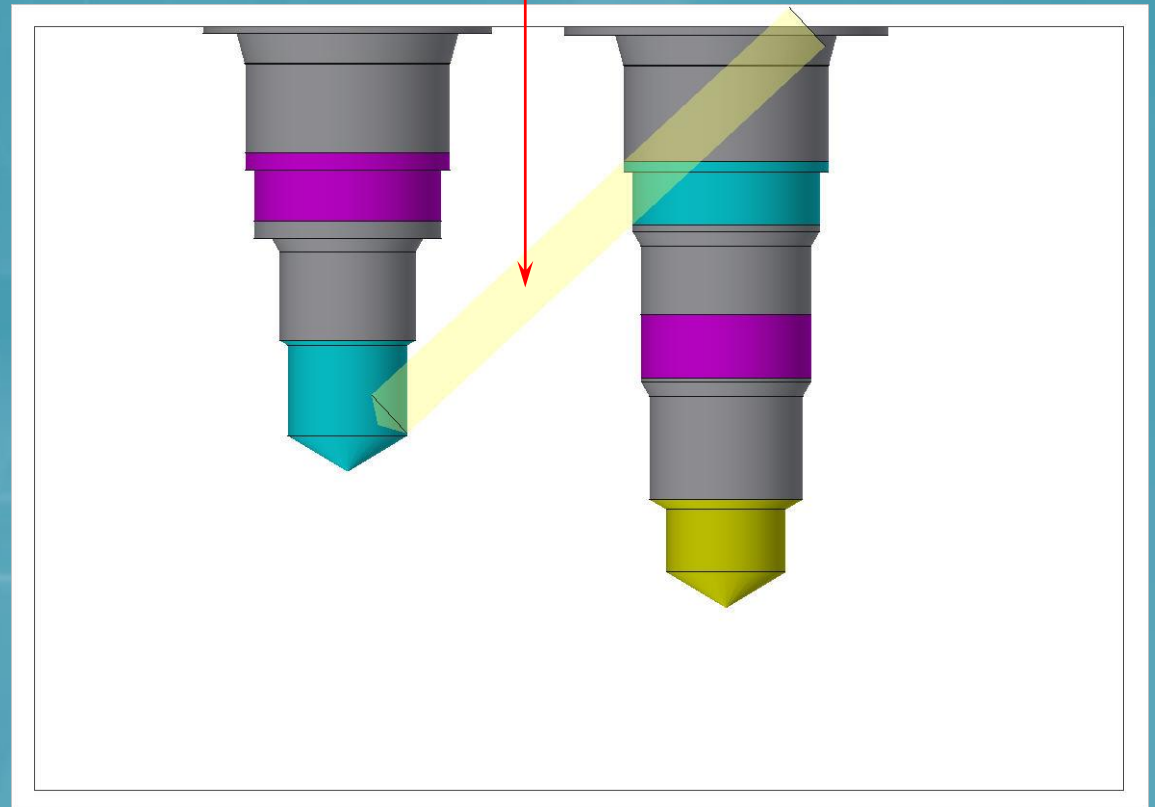



Mirror Footprint

Create a mirrored copy of a footprint on a mating manifold

Parent Manifold

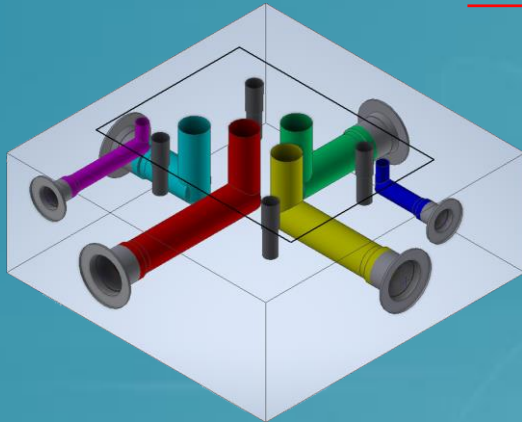

Specify required bolt holes for mating manifold

Mirror Footprint

Select

Bolt Holes
 Threaded
 Through
 With Counter Bore
 Drill from both ends

Source Cavity	Quantity	Library	Mating Cavity
1/4-20 UNC	4	Miscellaneous	Thru. Bolthole. Hole ...

O-ring Grooves
 Add to Mating Surface
 Type
 Groove Counter Bore

Port Name	Port Dia	Dash Number	ID	OD	Width
P	0.44	-014	1/2	5/8	1/16
A	0.44	-014	1/2	5/8	1/16
B	0.44	-014	1/2	5/8	1/16
T	0.44	-014	1/2	5/8	1/16
X	0.19	-010	1/4	3/8	1/16
Y	0.19	-010	1/4	3/8	1/16

Add optional O-ring grooves on corresponding ports

Mating Manifold

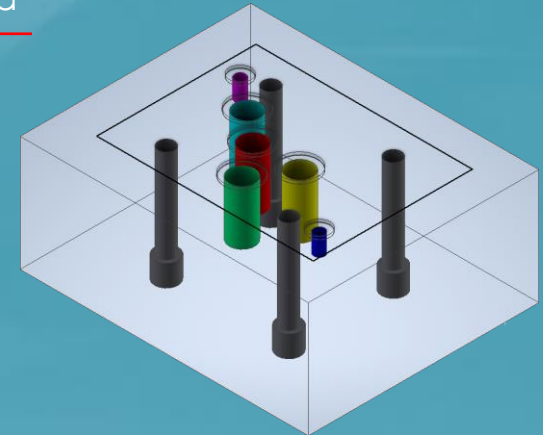

Assembly

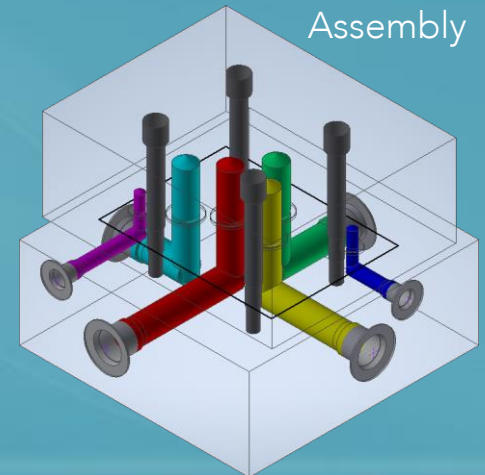



Make Footprint Outline

Make Footprint

Parent Cavity

Child Cavities

Component ID: A1

OEM Name: Custom Footprint

Cavity	Port Name	Dimension From
1	DH	<input checked="" type="checkbox"/>
BH	BH1	<input type="checkbox"/>
BH_Copy1	BH2	<input type="checkbox"/>
BH_Copy2	BH3	<input type="checkbox"/>
BH_Copy3	BH4	<input type="checkbox"/>
BH_Copy4	BH5	<input type="checkbox"/>
BH_Copy5	BH6	<input type="checkbox"/>
BH_Copy6	BH7	<input type="checkbox"/>

Footprint Outline... OK Cancel

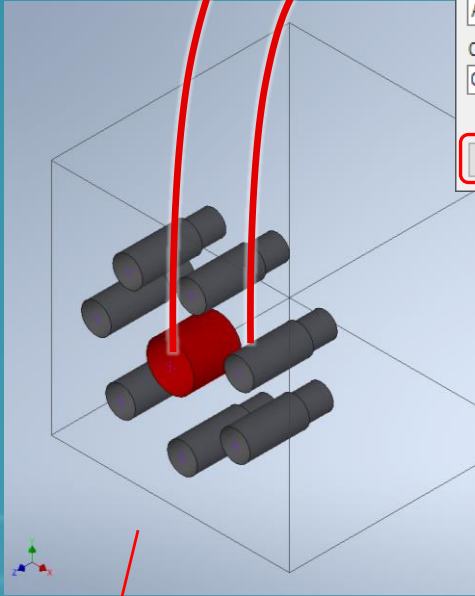

Select Parent, and Child cavities

Footprint Outline

Rectangular Circular

2

OK Cancel

Edit footprint outline dimensions

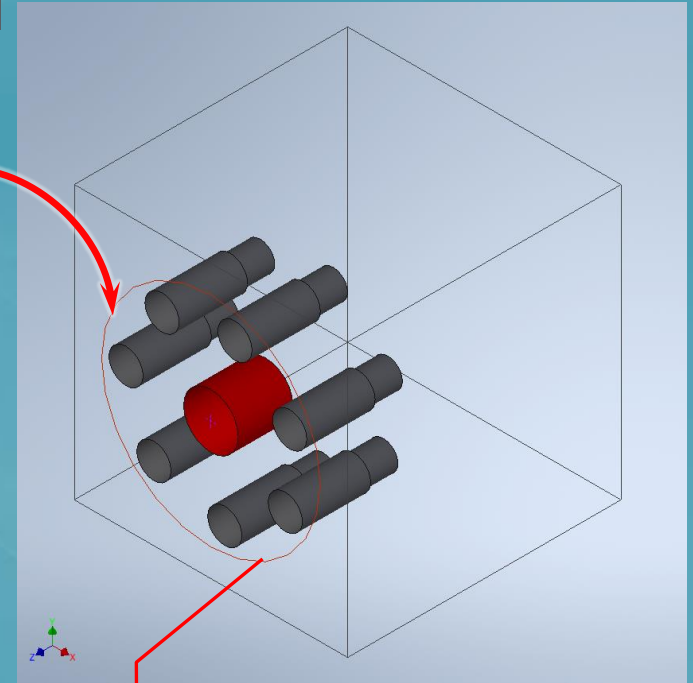

Footprint outline created



Dimension only Selected Cavity Types

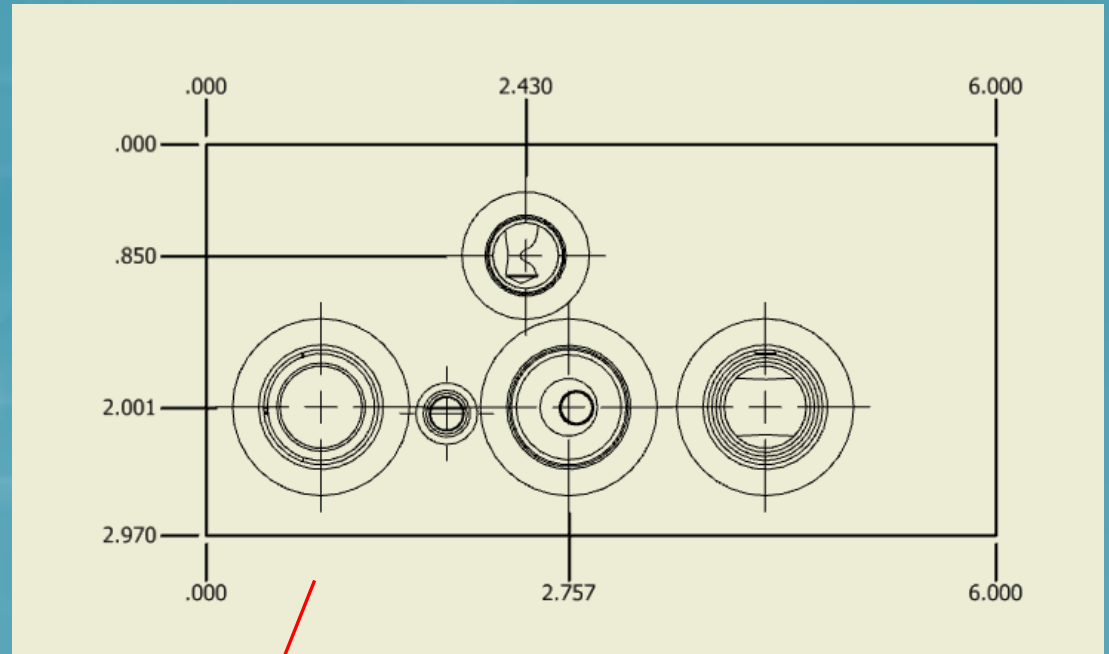
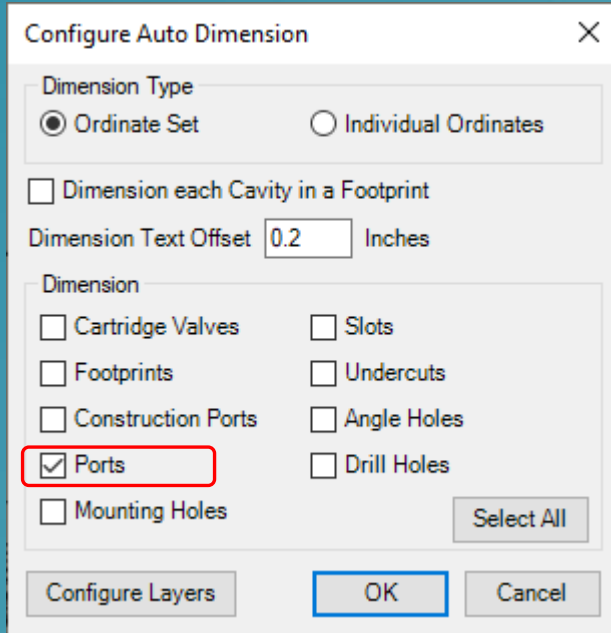

Selected cavity types dimensioned (Ports), while others left un-dimensioned



Create Cavity Dimensions as Individual Ordinates

Assign layers to cavity type dimensions in order to easily control the information shown

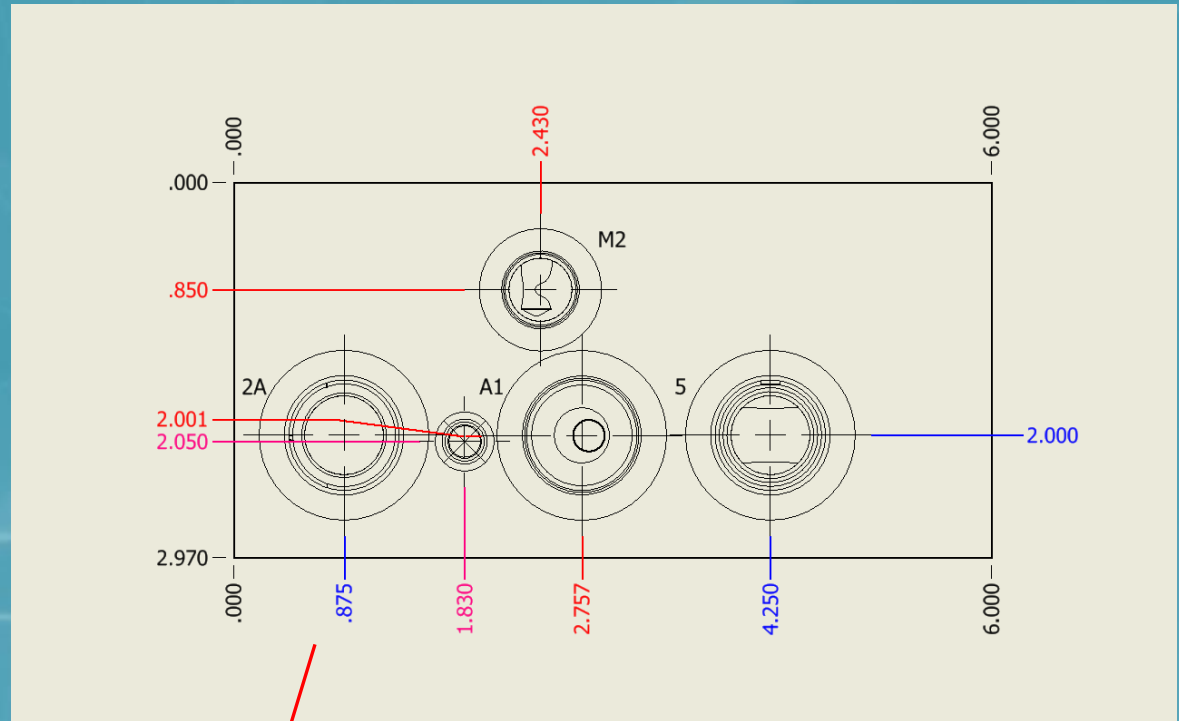
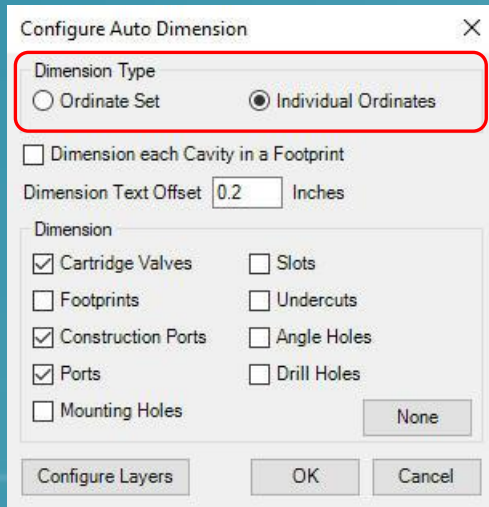

Each cavity type is assigned a layer and different layers have been given different colors through the Inventor Style Editor



Drawing Dimensions Automatically Updated

MDTools automatically updates the dimensioning of the drawing when the Part (Block) is modified

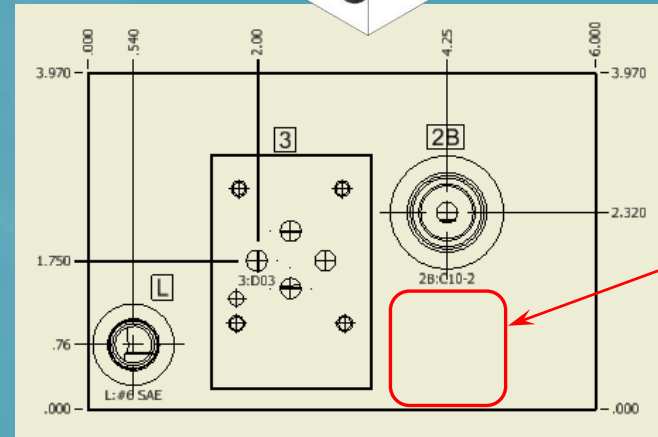
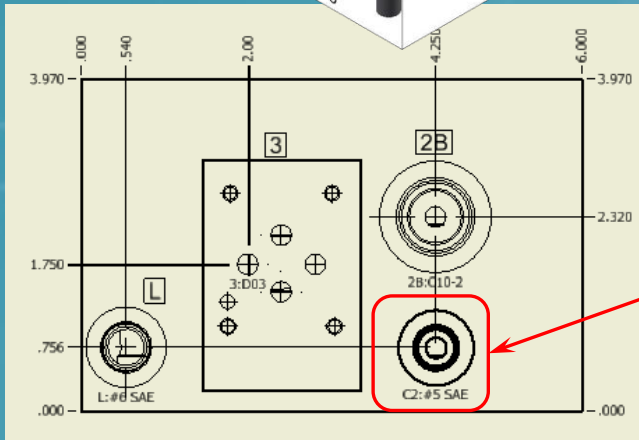
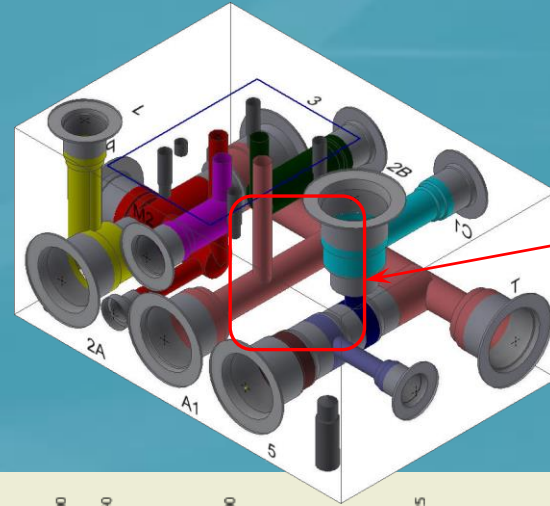
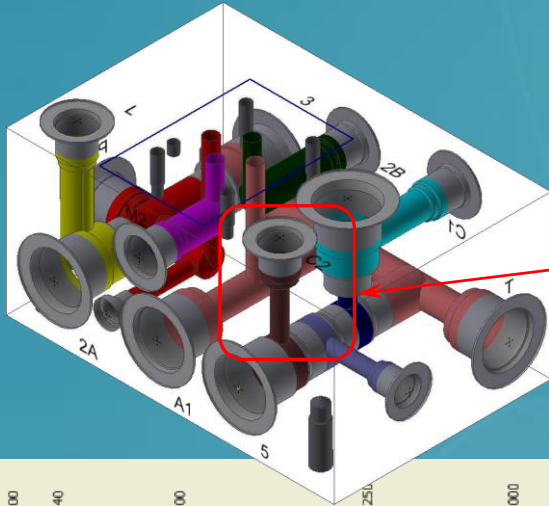



Machining Chart Automatically Updated

MDTools automatically updates the Machining Chart when the Part (Block) is modified

Machining Chart				
Name	Operation	Diameter	Depth	Location
2B	DRILL	0.250	2.000	(4.250/ 1.999)
	C10-2	1.344	0.031	
3-A	DRILL	1/4	1.000	(2.400/ 2.100)
3-B	DRILL	1/4	1.000	(2.400/ 1.420)
3-BH1	TAP DRILL	5/32	0.700	(3.010/ 2.600)
	TAP	#10-24	0.500	
3-BH2	TAP DRILL	5/32	0.700	(3.040/ 1.006)
	TAP	#10-24	0.500	
3-BH3	TAP DRILL	5/32	0.700	(1.760/ 1.006)
	TAP	#10-24	0.500	
3-BH4	TAP DRILL	5/32	0.700	(1.790/ 2.600)
	TAP	#10-24	0.500	
3-LP	DRILL	11/64	0.175	(1.760/ 1.301)
3-P	DRILL	0.250	2.000	(2.000/ 1.750)
3-T	DRILL	1/4	2.025	(2.810/ 1.750)
C2	DRILL	0.250	1.592	(4.250/ 0.756)
	FORM PORT	#6 SAE	0.031	
	TAP	9/16-18	0.531	
L	DRILL	0.438	2.000	(0.540/ 0.756)
	FORM PORT	#6 SAE	0.031	
	TAP	9/16-18	0.531	
L_SL	SLOT	0.250	2.500	(0.540/ 0.756)

Machining Chart				
Name	Operation	Diameter	Depth	Location
2B	DRILL	0.250	2.000	(4.250/ 1.999)
	C10-2	1.344	0.031	
3-A	DRILL	1/4	1.000	(2.400/ 2.100)
3-B	DRILL	1/4	1.000	(2.400/ 1.420)
3-BH1	TAP DRILL	5/32	0.700	(3.010/ 2.600)
	TAP	#10-24	0.500	
3-BH2	TAP DRILL	5/32	0.700	(3.040/ 1.006)
	TAP	#10-24	0.500	
3-BH3	TAP DRILL	5/32	0.700	(1.760/ 1.006)
	TAP	#10-24	0.500	
3-BH4	TAP DRILL	5/32	0.700	(1.790/ 2.600)
	TAP	#10-24	0.500	
3-LP	DRILL	11/64	0.175	(1.760/ 1.301)
3-P	DRILL	0.250	2.000	(2.000/ 1.750)
3-T	DRILL	1/4	2.025	(2.810/ 1.750)
L	DRILL	0.438	2.000	(0.540/ 0.756)
	FORM PORT	#6 SAE	0.031	
	TAP	9/16-18	0.531	
L_SL	SLOT	0.250	2.500	(0.540/ 0.756)

Updated Machining chart



Miscellaneous Lists Automatically Updated

MDTools automatically updates the Charts on the Miscellaneous lists Sheet when the Part (Block) is modified

ENGRAVED TEXT CHART						
TEXT	FACE	X	Y	ROTATION	FONT	TEXT HEIGHT
2B	1	4.048	2.77		Arial Unicode MS	0.2
3	1	2.26	3.077		Arial Unicode MS	0.2
C2	1	4.807	0.611		Arial Unicode MS	0.2
L	1	0.806	1.332		Arial Unicode MS	0.2
2A	2	0.782	2.9		Arial Unicode MS	0.2
5	2	4.652	2.869		Arial Unicode MS	0.2
A1	2	3.072	2.885		Arial Unicode MS	0.2
M2	2	2.176	0.31		Arial Unicode MS	0.2
P	4	1.86	1.307		Arial Unicode MS	0.2
T	5	3.118	1.228		Arial Unicode MS	0.2
4	6	0.623	2.885		Arial Unicode MS	0.2
C1	6	4.446	1.569		Arial Unicode MS	0.2
M1	6	2.621	1.8		Arial Unicode MS	0.2

ENGRAVED TEXT CHART						
TEXT	FACE	X	Y	ROTATION	FONT	TEXT HEIGHT
2B	1	4.048	2.77		Arial Unicode MS	0.2
3	1	2.26	3.077		Arial Unicode MS	0.2
L	1	0.806	1.332		Arial Unicode MS	0.2
2A	2	0.782	2.9		Arial Unicode MS	0.2
5	2	4.652	2.869		Arial Unicode MS	0.2
A1	2	3.072	2.885		Arial Unicode MS	0.2
M2	2	2.176	0.31		Arial Unicode MS	0.2
P	4	1.86	1.307		Arial Unicode MS	0.2
T	5	3.118	1.228		Arial Unicode MS	0.2
4	6	0.623	2.885		Arial Unicode MS	0.2
C1	6	4.446	1.569		Arial Unicode MS	0.2
M1	6	2.621	1.8		Arial Unicode MS	0.2

For example, when the cavity C2 is deleted from the block, then upon re-opening the drawing, the charts will be updated with C2 gone

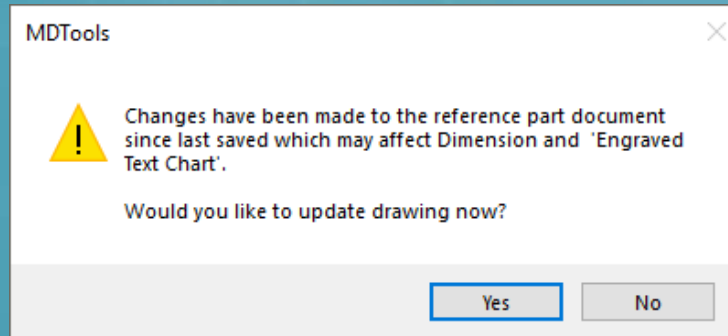



Balloons/Annotations Automatically Updated

Balloons and all MDTTools drawing annotations updated when the Part (Block) is modified

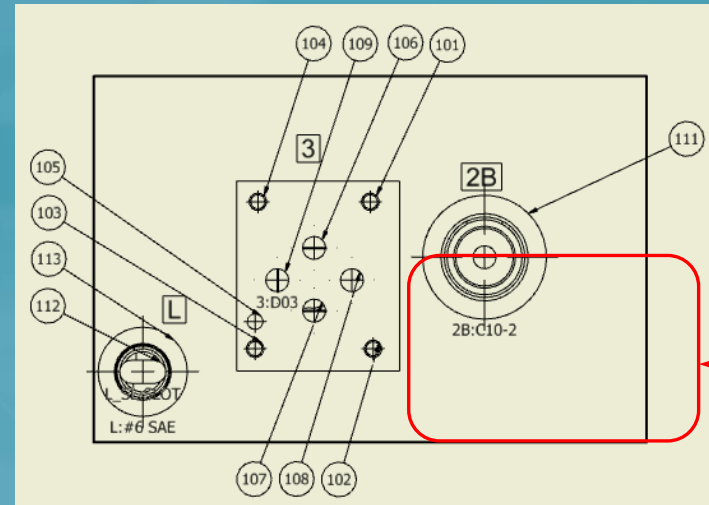
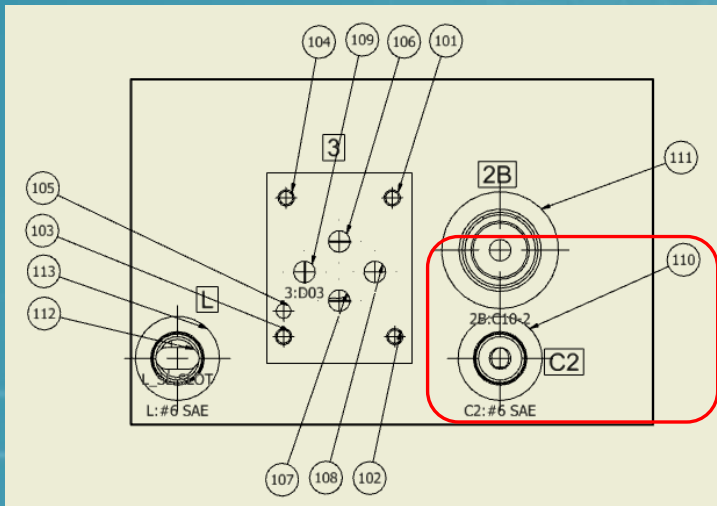



Fast and Secure Cloud-based License Activation

Two Cloud-based license options available

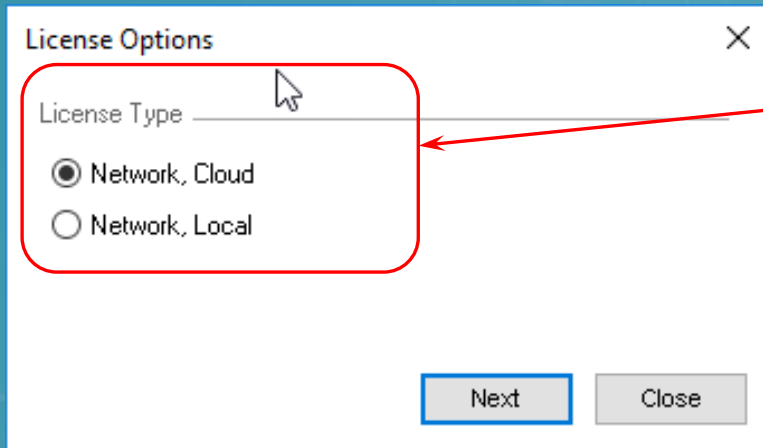

Cool features of Cloud licensing

- Fast and Secure Online Activation
- Access License from anywhere, anytime via Internet
- No need to use a USB dongle
- Network, Local - license type provides MDTtools license from the Local License Server Manager over the LAN



MDTools Help: Online and Offline

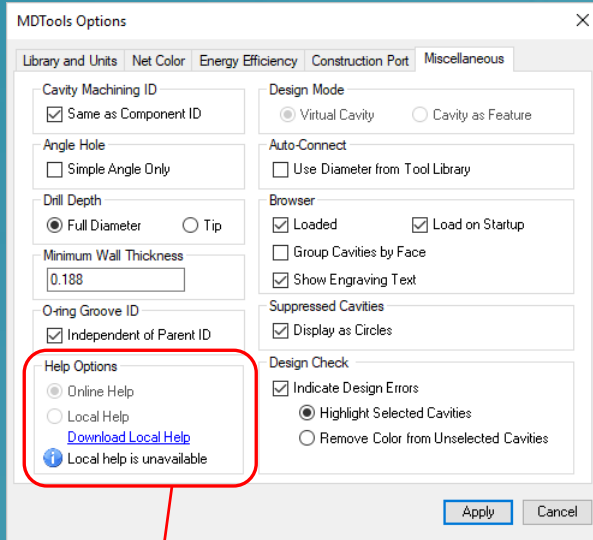

Local Help can be downloaded for offline viewing

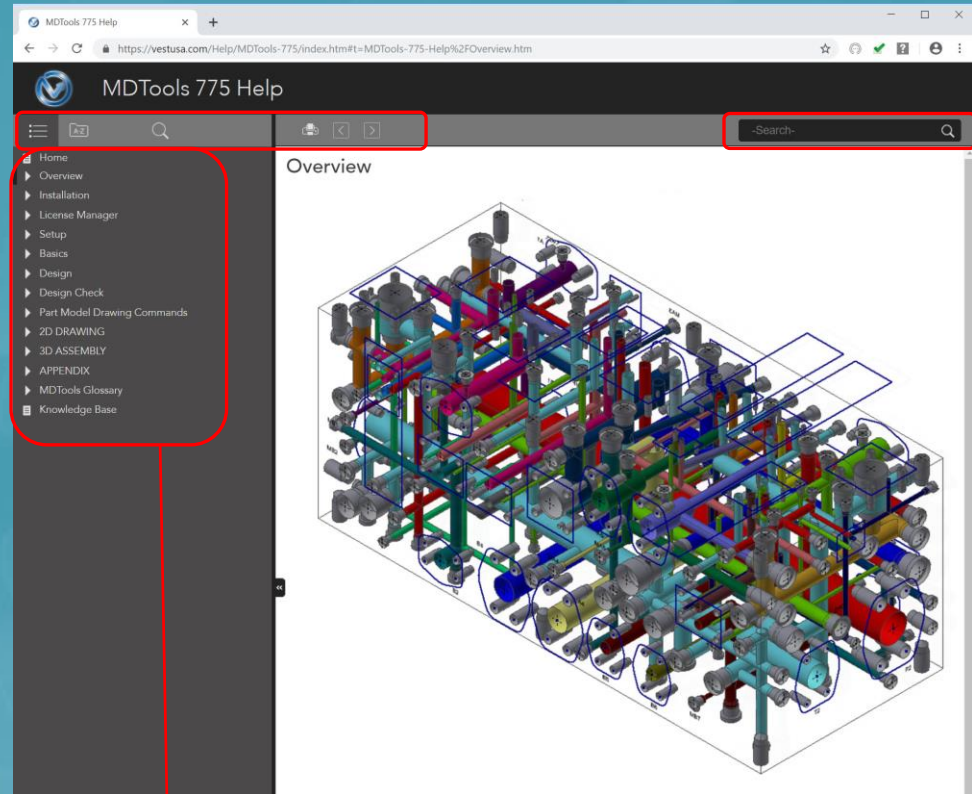

- Online Help, always up-to-date
- Smart Search
- Glossary
- Integration with Knowledge base
- Structured task-oriented navigation
- Index with Filter keywords



Improved Offset Connection

Improved offset connections create a better flow path with reduced pressure drop

Offset connection
in MDTools 770

Improved
Offset connection
in MDTools 775

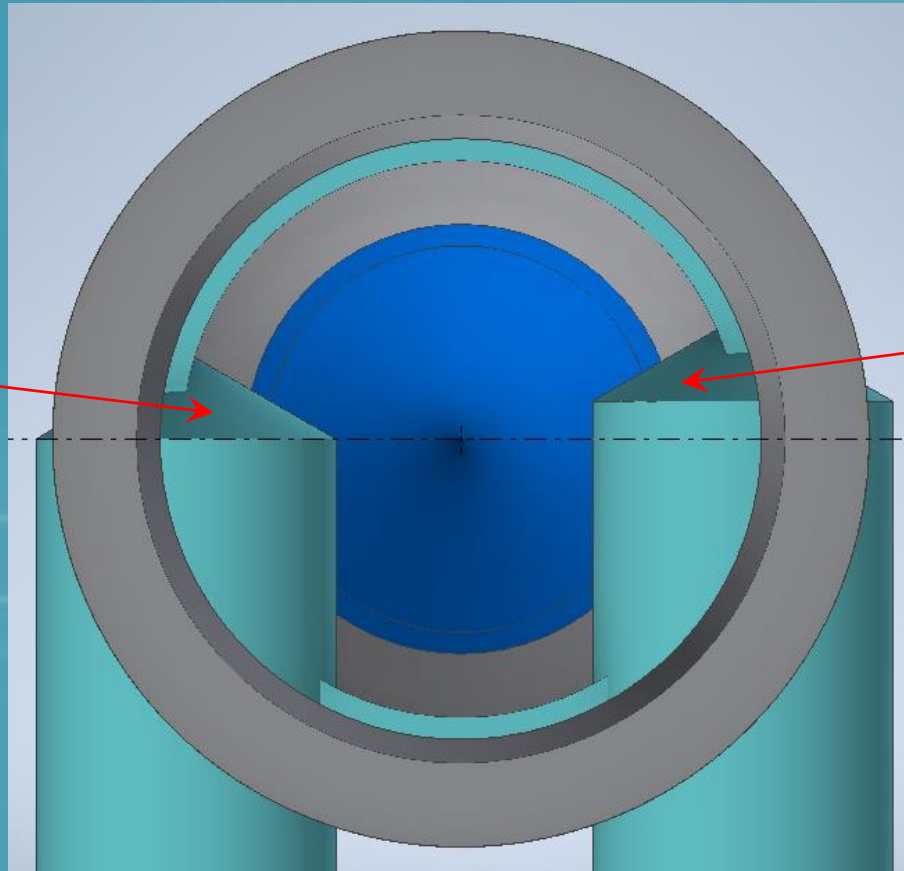



Suppressed State of Undercut and Slot Displayed

MDTools Browser displays suppressed and unsuppressed icons

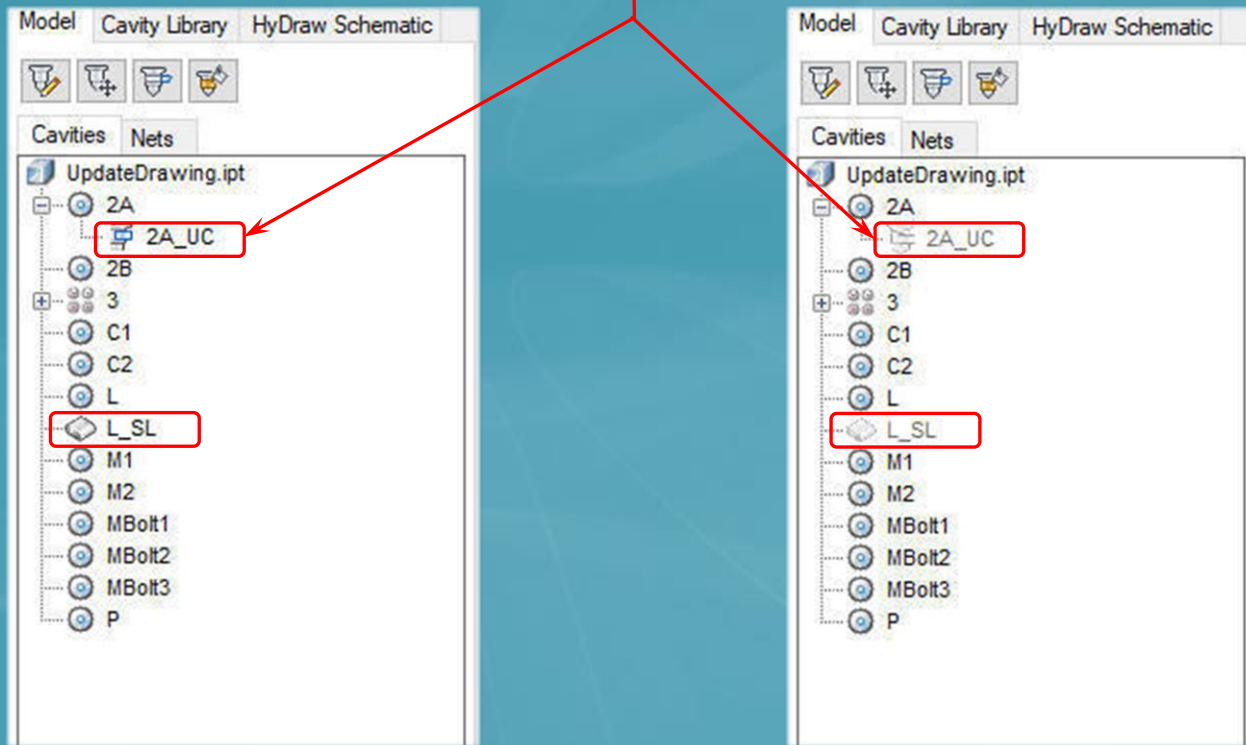



MDTools Library Manager 2019

Materials section included in MDTools Library Manager 2019

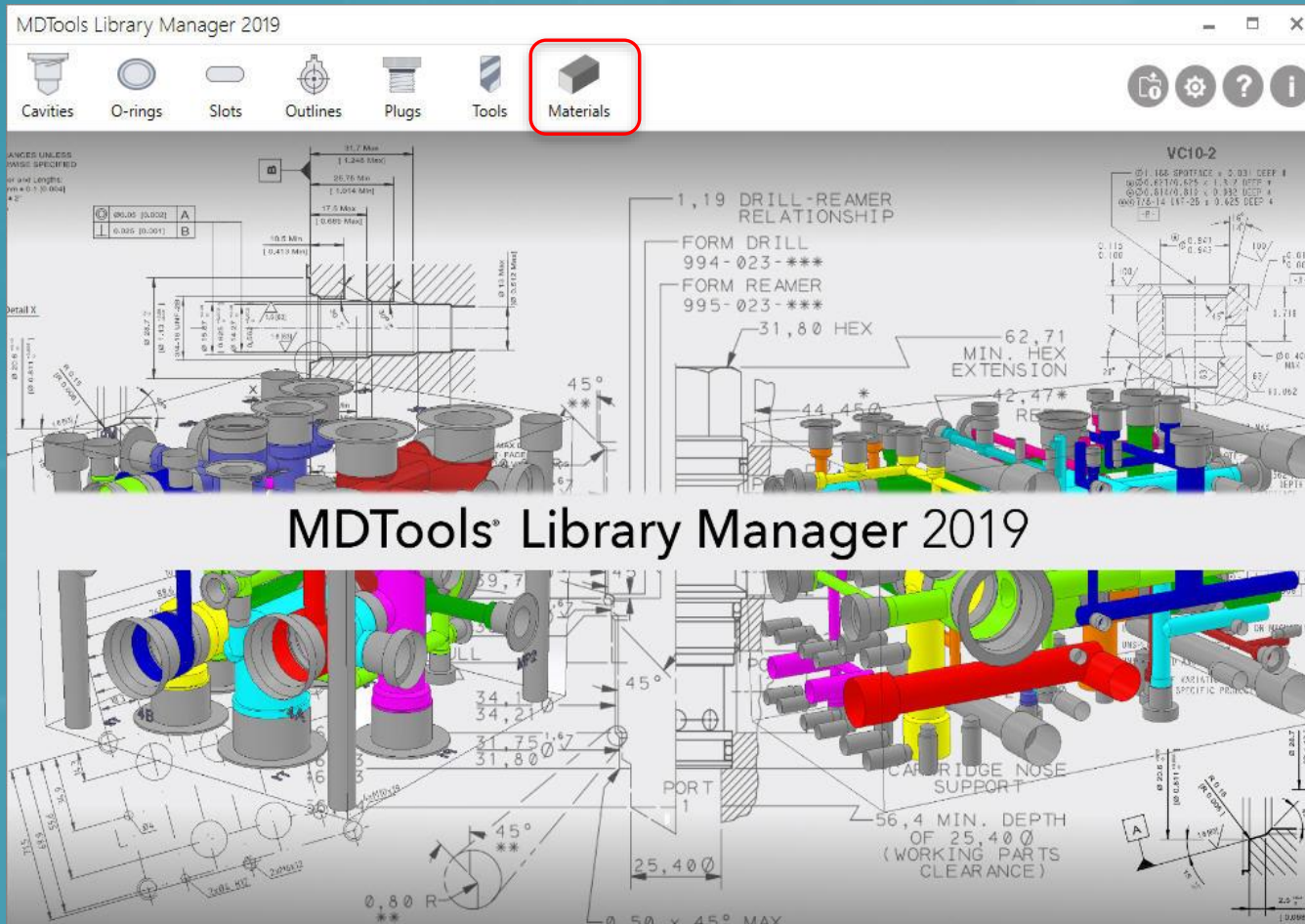

MDTools® Library Manager 2019



Manage Material Bars

Manage cross section and machining allowance of bars

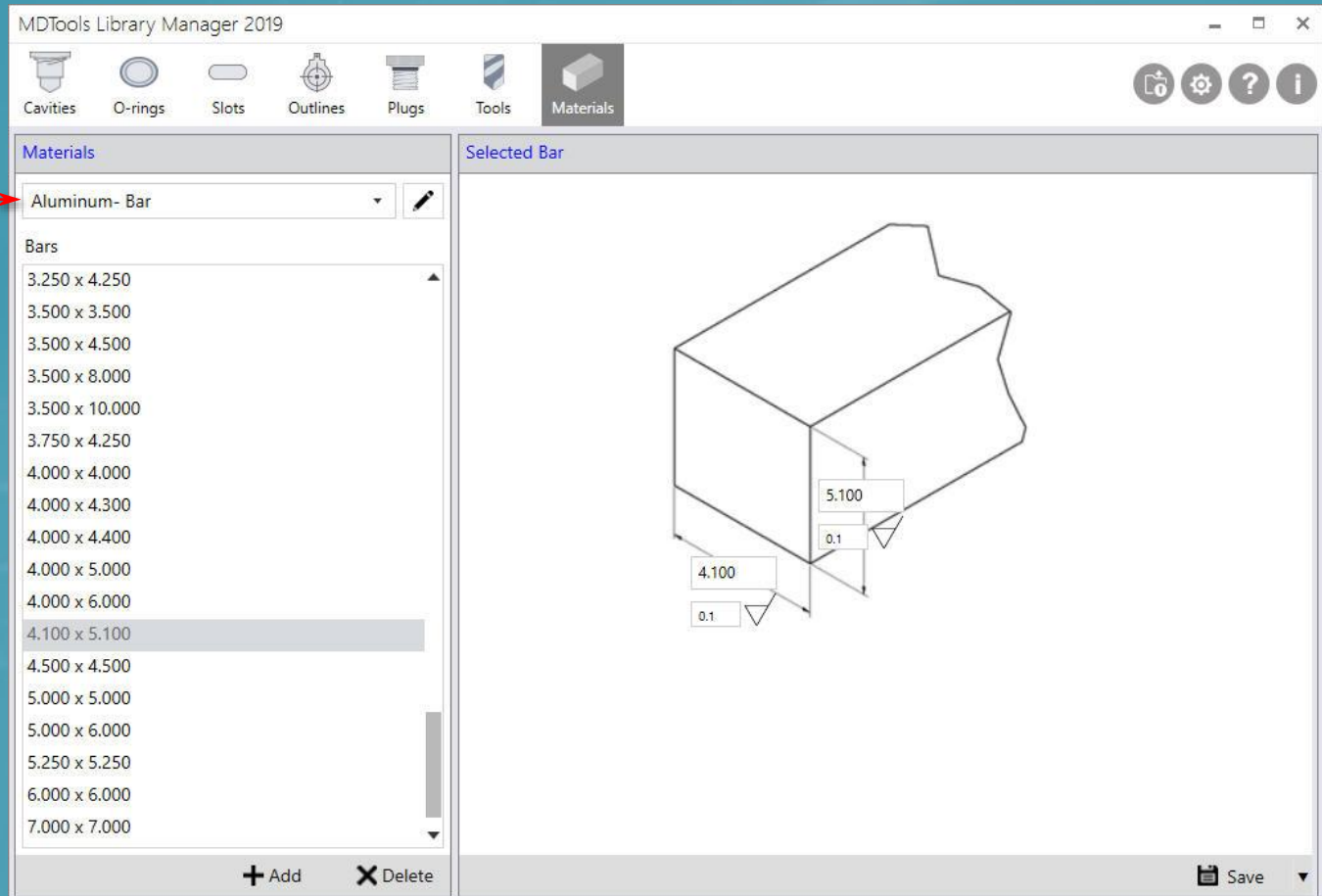

Select Material for Bar



Manage Material Plates

Manage thickness and machining allowance of plates

Select Material for Plate

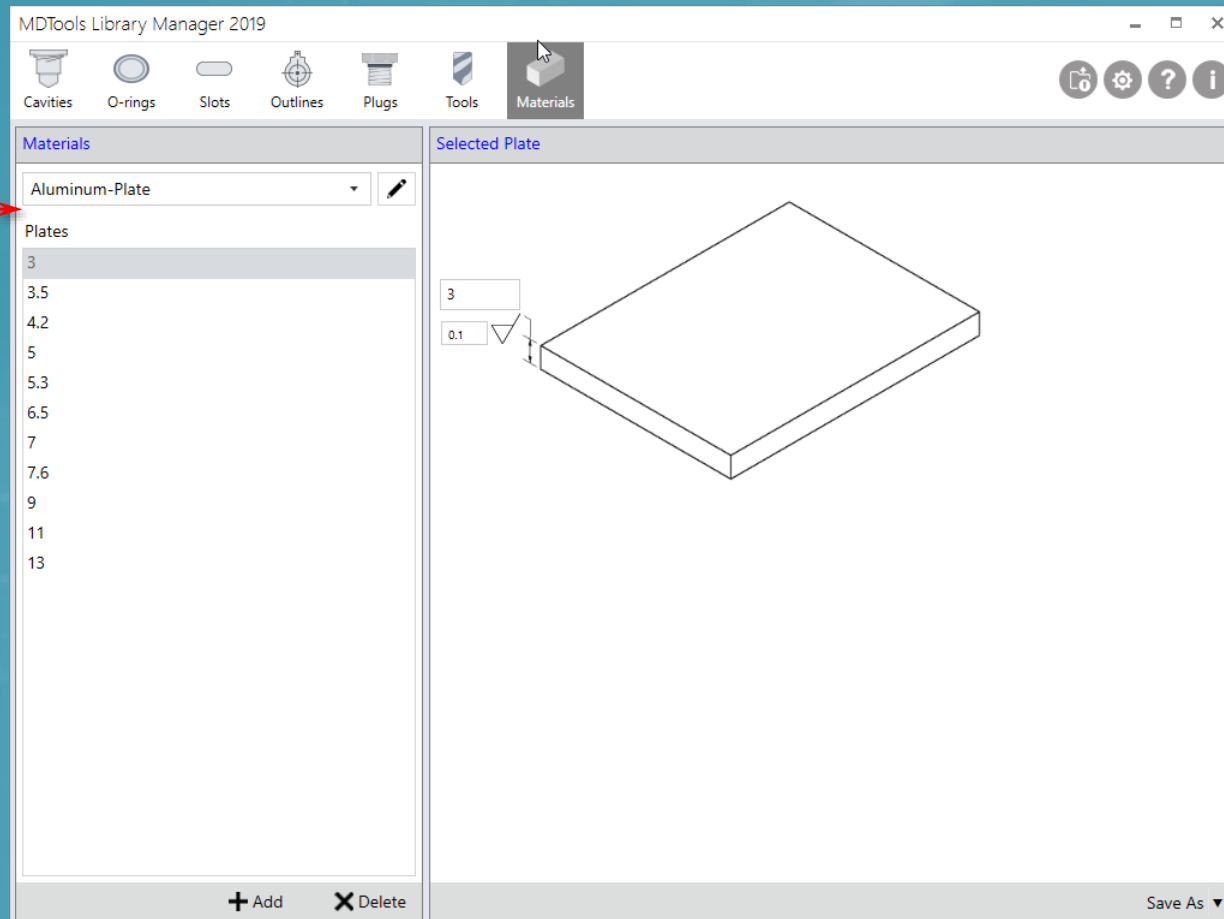



Add/Modify Materials and Allowances

Manage material cross section and machining allowance of bars and plates

The screenshot shows the MDTools Library Manager 2019 interface. The 'Materials' tab is active, displaying a list of materials under the 'Aluminum- Bar' category. A red box highlights the edit icon (a pencil) next to the 'Aluminum- Bar' header. A red arrow points from this icon to the 'Manage Materials' dialog box on the right. The dialog box shows the following details:

Name	Aluminum- Bar
Type	Bar
Machining Allowance	0.1

At the bottom of the dialog box, there are buttons for '+ Add', 'Update', and 'Delete'.



Do more...

MDTools® 775

manifold design app

USA: +1 (248) 649-9550

sales@VESTusa.com

Europe: +39 328 695 70 01

carlo@VESTusa.com

